

173012 Polymer Concrete Box & Cover

COVER VIEW

TOP VIEW

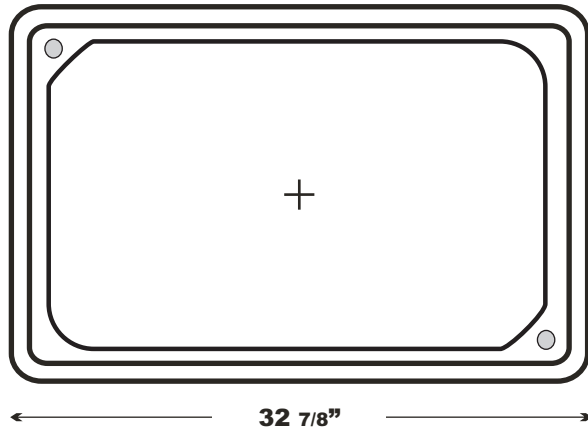

32 7/8"



17 1/2"

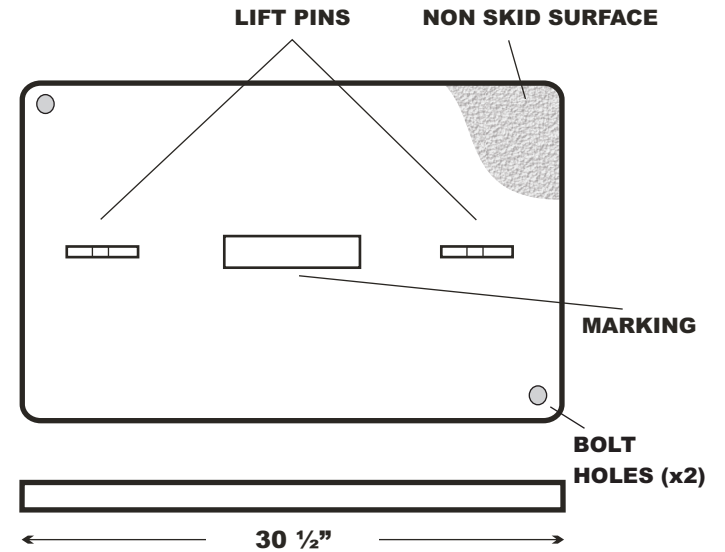

LIFT PINS

NON SKID SURFACE

MARKING

BOLT HOLES (x2)

2"

30 1/2"

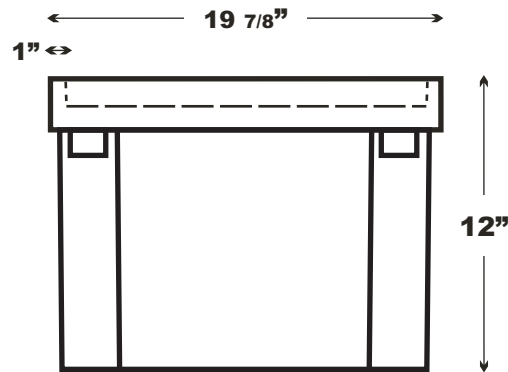

19 7/8"

1"

12"

END VIEW

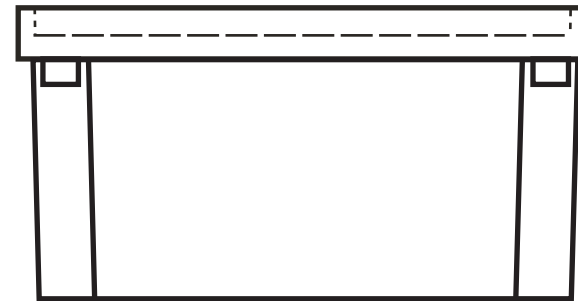

SIDE VIEW

Cover Bolt Ring Insert Diagram

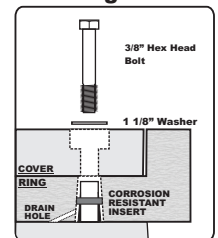

Part No. 173012 PC		
BODY: POLYMER CONCRETE		
COVER: POLYMER CONCRETE		
Weight 145 lbs.	Tolerance +/- 1/8"	Weight Load 20k
Date July 8 2009	File 173012 PC	



Martin Enterprises
"Your Underground Enclosure Experts"

WWW.MARTINFRP.COM

7231 Boulder Ave. #262
Highland, CA 92346
Tel 951.928.8713
Fax 951.928.4623

This product design is the sole property of Martin Enterprises. This design is NOT to be altered unless written permission is allowed by Martin Enterprises only.